

## Cast iron Gate Valve outside screw stainless steel trim PN16 handwheel operated High Temperature BS 5150/ANSI Class 125 with proximity

### Main characteristics

- Manufactured Italy in accordance with BS5150
- Face-to-face length according to EN 558-1, basic series 3
- Flanged according to ANSI B16.1 with flat face (EN 1092-2 PN 16 available)
- Outside screw thread clockwise closing, adjustable stuffing box
- Minimal pressure drop
- Hydrostatically tested according to EN 12266-1: Test type P11-P12
- Pressure Equipment Directive 2014/68/UE art. 13 Group 1
- 100% full bore

### Field of application

- Industrial plants
- Sewage Water
- Water treatment
- Air-conditioning systems (HVAC)
- Central heating and cooling circuits
- Aggressive fluids
- Tanks
- Fire sprinkler systems

### Corrosion protection

- Standard version: externally coated with Phenolic-oil resin with zinc-phosphate high corrosion resistance painting Grey Ral 7011
- On request: integrally epoxy coated
- Customized color available



### Ratings

Working temperature (°C)	-10 to +120	+120 to +150
Max Working pressure (bar)	16	14

### Hydrostatically tested according to EN 12266-1 (bar)

P11 Body test	P12 Seat Test water	P12 Seat test air
24	18	6

### Material specification

Nr	Parts	Material	Specification
1	Lock nut	CW614N Drawn brass	EN 12164
2	Handwheel	EN-GJL-150 grey cast iron	EN 1561
3	Motherscrew	CB 754-S GM Cast brass	EN 1982
4	Yoke	EN-GJL-250 grey cast iron	EN 1561
5	Packing gland	EN-GJL-250 grey cast iron	EN 1561
6	Packing	Ptfe	ASTM 4894
7	Gasket	Fasit 205	-
8	Stem	X12Cr13 Stainless steel	AISI 410
9	Bonnet	EN-GJL-250 grey cast iron	EN 1561
10	Gasket	Fasit 205	-
11	Motherscrew	Carcon steel	A 105
12	Wedge DN 50-DN 65	Carcon steel +	
		AISI 304L stainless steel	A105+AISI304L
12	Wedge DN 80- DN 300	EN-GJL-250 grey cast iron	EN 1561
13	Seat	Stainless steel	AISI 304L
14	Body	EN-GJL-250 grey cast iron	EN 1561
15	Nut	Zinc-plated 8.8 carbon steel	ISO 4032
16	Screw	Zinc-plated 8.8 carbon steel	EN ISO 4017
17	Tie rod	Zinc-plated 8.8 carbon steel	-
18	Pin	Stainless steel	AISI 316
19	Proximity	-	-

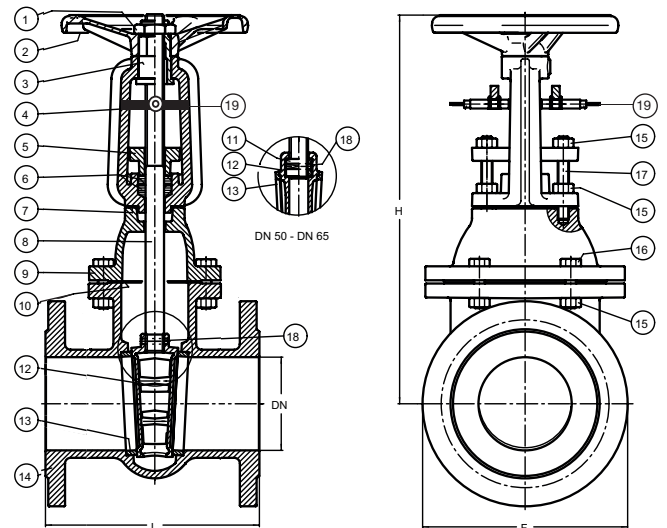

### Technical data

DN	50	65	80	100	125	150	200	250	300
F mm	165	185	200	229	250	285	340	405	483
L mm	178	190	203	229	254	267	292	330	356
H mm	275	335	380	435	495	585	710	830	965
Weight Kg	13	17	23	32	43	56	89	134	181
Handwheel Ø mm	150	175	175	200	200	225	225	250	300
Turns open/close nr	12,5	16	20	25	25	30	40	50	60
Max torque gate closing Nm	35	45	50	60	60	80	90	100	120
Kvs value	250	430	790	1.250	1.960	2.790	2.880	4.306	6.380

EN\_260prox - Edition 07/2024 • Maran e Peracini srl assumes no responsibility or liability for typographical errors or omissions and reserves the right to change without notice.

## Valvola a saracinesca in ghisa grigia a Corpo Ovale vite esterna sede inox AISI304L PN16 per Alte Temperature BS5150/ANSI Class 125 con proximity

### Principali caratteristiche

- Prodotta in Italia in accordo a BS 5150
- Scartamento secondo EN 558-1, serie 3
- Connessioni flangiata secondo ANSI B16.1 a flangia piana (EN 1092-2 PN16 secondo altre specifiche disponibili su richiesta)
- Stelo interno, chiusura in senso orario, tenuta secondaria sullo stelo regolabile tramite premistoppa
- Minima perdita di carico
- Testata idraulicamente secondo EN 12266-1: Test tipo P11-P12
- Conforme alla Direttiva Attrezzature in Pressione PED 2014/68/UE art. 13 Fluidi di gruppo 1
- 100% passaggio totale

### Settori di utilizzo

- Impianti industriali
- Acque reflue
- Impianti trattamento acque
- Sistemi di condizionamento aria (HVAC)
- Centrali termiche e circuiti di raffreddamento
- Fluidi aggressivi
- Serbatoi
- Alimentazione sistemi antincendio Sprinkler

### Protezione dalla corrosione

- Versione Standard: rivestita esternamente con vernice ad alta resistenza alla corrosione con resina oleofenolica ai fosfati di zinco Grigio Ral 7011
- Su richiesta: verniciatura integrale epossidica
- Altre tonalità disponibili



### Condizioni di esercizio

Temperature fluido (°C)	-10 to +120	+120 to +150
Massima pressione fluido (bar)	16	14

### Test idraulico secondo EN 12266-1 (bar)

P11 Corpo	P12 Sedi (acqua)	P12 Sedi (aria)
24	18	6

### Specifica materiali

Nr	Parte	Materiale	Norma
1	Controdado	CW614N ottone trafilato	EN 12164
2	Volantino	EN-GJL-150 ghisa grigia	EN 1561
3	Madrevite	CB 754-S GM ottone fuso	EN 1982
4	Cavallotto	EN-GJL-250 ghisa grigia	EN 1561
5	Premistoppa	EN-GJL-250 ghisa grigia	EN 1561
6	Baderna	Ptfe	ASTM 4894
7	Guarnizione	Fasit 205	-
8	Asta	X12Cr13 acciaio inossidabile	AISI410
9	Cappello	EN-GJL-250 ghisa grigia	EN 1561
10	Guarnizione	Fasit 205	-
11	Madrevite	Acciaio al carbonio	A 105
12	Cuneo DN 40-DN 65	Acciaio al carbonio + AISI 304L acciaio inossidabile	A105+AISI 304L
12	Cuneo DN 80- DN 300	EN-GJL-250 ghisa grigia	EN 1561
13	Sedi	Acciaio inossidabile	AISI 304L
14	Corpo	EN-GJL-250 ghisa grigia	EN 1561
15	Dado	Acciaio zincato 8.8	ISO 4032
16	Vite	Acciaio zincato 8.8	EN ISO 4017
17	Tirante	Acciaio zincato 8.8	-
18	Spina	Acciaio inossidabile	AISI 316
19	Proximity	-	-

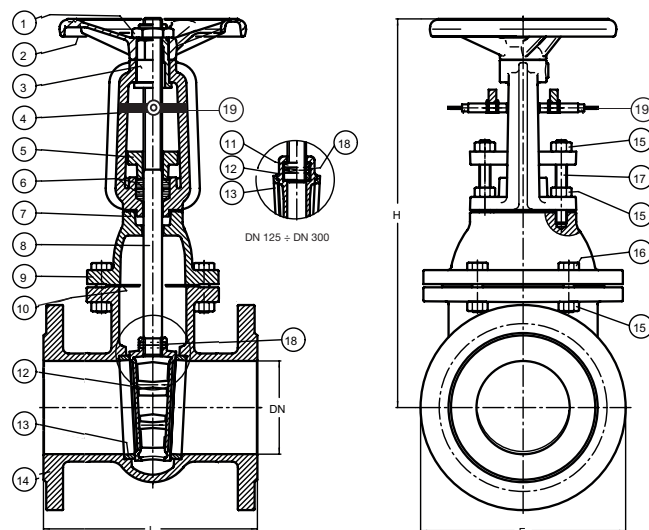

### Dati tecnici

DN	50	65	80	100	125	150	200	250	300
F mm	165	185	200	229	250	285	340	405	483
L mm	178	190	203	229	254	267	292	330	356
H mm	275	335	380	435	495	585	710	830	965
Peso Kg	13	17	23	32	43	56	89	134	181
Volantino Ø mm	150	175	175	200	200	225	225	250	300
Giri apertura/chiusura nr	12,5	16	20	25	25	30	40	50	60
Momento torcente in chiusura Nm	35	45	50	60	60	80	90	100	120
Perdite di carico Kvs	250	430	790	1.250	1.960	2.790	2.880	4.306	6.380

IT\_260prox - Edizione 07/2024 • Maran e Peracini srl si riserva il diritto di apportare variazioni senza preavviso.