

Cast iron Gate Valve inside screw bronze trim PN16 handwheel operated High Temperature

Main characteristics

- Manufactured in Italy in accordance with EN 1171
- Face-to-face length according to EN 558-1, basic series 14
- Flanged according to EN 1092-2 PN16 with raised face, undrilled, PN10 or other specifications on request
- Inside screw thread clockwise closing, adjustable stuffing box
- Minimal pressure drop
- Hydrostatically tested according to EN 12266-1: Test type P11-P12 Rate A
- Pressure Equipment Directive 2014/68/UE Group 1
- 100% full bore
- Gate valves are bi-directional and can be installed in any position. However, the preferred orientation is with the stem pointing vertically upwards.

Field of application

- Industrial plants
- Sewage water
- Water treatment
- Air-conditioning systems (HVAC)
- Central heating and cooling circuits
- Aggressive fluids
- Tanks
- Shipyard

Corrosion protection

- Standard version: externally coated with Phenolic-oil resin with zinc-phosphate high corrosion resistance painting Grey Ral 7011
- On request: integrally epoxy coated
- Customized color available



Ratings

Working temperature (°C)	-10 to +120	+120 to +150
Max Working pressure (bar)	16	14

Hydrostatically tested according to EN 12266-1 (bar)

P11 Body test	P12 Seat Test water	P12 Seat test air
24	18	6

Material specification

Nr	Parts	Material	Specification
1	Screw	Zinc-plated 8.8 carbon steel	EN ISO 4017
2	Washer	Zinc-plated carbon steel	EN 7092
3	Handwheel	EN-GJL-250 grey cast iron	EN 1561
4	Packing gland	EN-GJL-250 grey cast iron	EN 1561
5	Packing	Ptfe	ASTM 4894
6	Stuffing box	EN-GJL-250 grey cast iron	EN 1561
7	Gasket	Fasit 205	-
8	Stem	CW614N Drawn brass	EN 12164
9	Bonnet	EN-GJL-250 grey cast iron	EN 1561
10	Gasket	Fasit 205	-
11	Motherscrew	CB 754-S GM Cast brass	EN 1982
12	Wedge DN 40-DN 100	Cast bronze CuSn5Zn5Pb5-B	1982
12	Wedge DN 125-DN 300	EN-GJL-250 grey cast iron	EN 1561
13	Seats	Cast bronze CuSn5Zn5Pb5-B	1982
14	Body	EN-GJL-250 grey cast iron	EN 1561
15	Nut	Zinc-plated 8.8 carbon steel	ISO 4032
16	Screw	Zinc-plated 8.8 carbon steel	EN ISO 4017
17	Tie rod	Zinc-plated 8.8 carbon steel	-

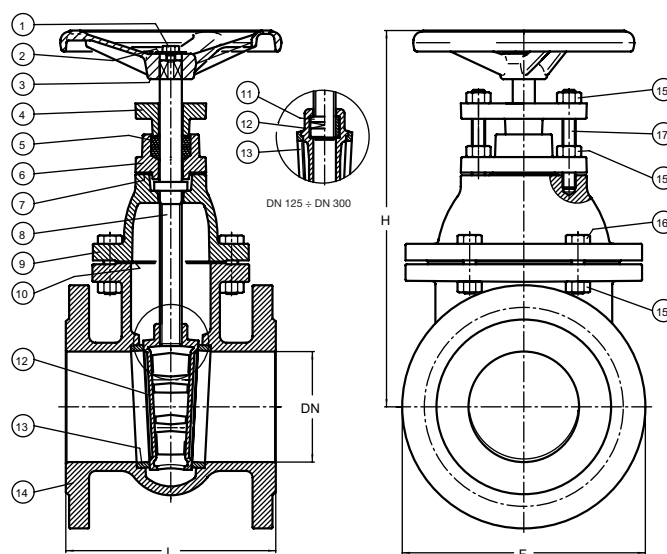

Technical data

DN	40	50	65	80	100	125	150	200	250	300
F mm	150	165	185	200	220	250	285	340	405	460
L mm	140	150	170	180	190	200	210	230	250	270
H mm	230	245	290	315	355	415	460	545	635	725
Weight Kg	10	12	16	20	26	35	45	67	91	124
Handwheel Ø mm	125	150	175	175	200	200	225	225	250	300
Turns open/close nr	10	12,5	16	20	25	25	30	40	50	60
Max torque gate closing Nm	30	30	35	35	40	45	45	60	65	70
Kvs value	107	250	430	790	1.250	1.960	2.790	2.880	4.306	6.380

EN_105bzn - Edition 11/2018 • Maran e Peracini srl assumes no responsibility or liability for typographical errors or omissions and reserves the right to change without notice.

Valvola a saracinesca in ghisa grigia a Corpo Piatto vite interna sede bronzo PN16 per Alte Temperature

Principali caratteristiche

- Prodotta in Italia in accordo a EN 1171
- Scartamento secondo EN 558-1, serie 14
- Connessioni flangiate secondo EN 1092-2 PN16 con risalto (secondo altre specifiche disponibili su richiesta)
- Stelo interno, chiusura in senso orario, tenuta secondaria sullo stelo regolabile tramite premistoppa
- Minima perdita di carico
- Testata idraulicamente secondo EN 12266-1: Test tipo P11-P12 Rate A
- Conforme alla Direttiva Attrezzature in Pressione PED 2014/68/UE art. 13 Fluidi di gruppo 1
- 100% passaggio totale

Settori di utilizzo

- Impianti industriali
- Acque di mare
- Carburanti
- Fluidi aggressivi
- Serbatoi
- Cantieri navali

Protezione dalla corrosione

- Versione Standard: rivestita esternamente con vernice ad alta resistenza alla corrosione con resina oleofenolica ai fosfati di zinco Grigio Ral 7011
- Su richiesta: verniciatura integrale epossidica
- Altre tonalità disponibili

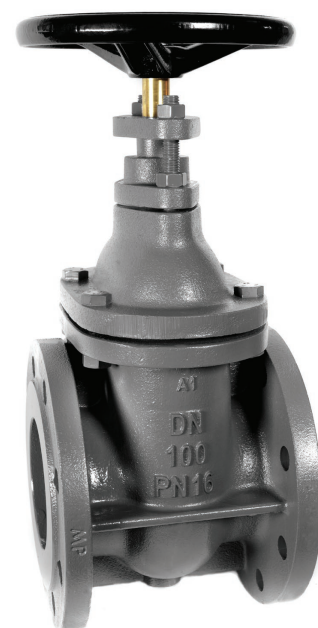

Condizioni di esercizio

Temperature fluido (°C)	-10 to +120	+120 to +150
Massima pressione fluido (bar)	16	14

Test idraulico secondo EN 12266-1 (bar)

P11 Corpo	P12 Sedi (acqua)	P12 Sedi (aria)
24	18	6

Specifica materiali

Nr	Parte	Materiale	Norma
1	Vite	Acciaio Zincato 8.8	EN ISO 4017
2	Rondella	Acciaio Zincato	EN 7092
3	Volantino	EN-GJL-250 ghisa grigia	EN 1561
4	Premistoppa	EN-GJL-250 ghisa grigia	EN 1561
5	Baderna	Ptfe	ASTM 4894
6	Porta stoppa	EN-GJL-250 ghisa grigia	EN 1561
7	Guarnizione	Fasit 205	-
8	Asta	CW614N ottone trafilato	EN 12164
9	Cappello	EN-GJL-250 ghisa grigia	EN 1561
10	Guarnizione	Fasit 205	-
11	Madrevite	CB 754-S GM ottone fuso	EN 1982
12	Cuneo DN 40-DN 100	CuSn5Zn5Pb5-B bronzo fuso	EN 1982
12	Cuneo DN 125-DN 300	EN-GJL-250 ghisa grigia	EN 1561
13	Sedi	CuSn5Zn5Pb5-B bronzo fuso	EN 1982
14	Corpo	EN-GJL-250 ghisa grigia	EN 1561
15	Dado	Acciaio Zincato 8.8	ISO 4032
16	Vite	Acciaio Zincato 8.8	EN ISO 4017
17	Tirante	Acciaio Zincato 8.8	-

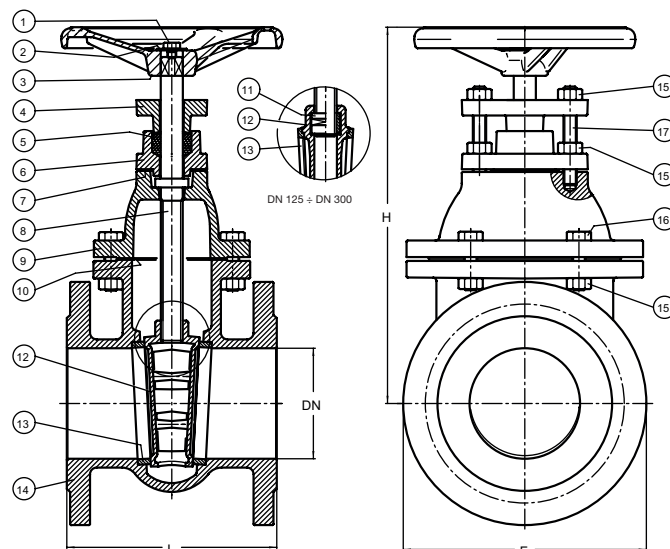

Dati tecnici

DN	40	50	65	80	100	125	150	200	250	300
F mm	150	165	185	200	220	250	285	340	405	460
L mm	140	150	170	180	190	200	210	230	250	270
H mm	230	245	290	315	355	415	460	545	635	725
Peso Kg	12	16	17	22	27	33	43	68	92	125
Volantino Ø mm	125	150	175	175	200	200	225	225	250	300
Giri apertura/chiusura nr	10	12,5	16	20	25	25	30	40	50	60
Momento torcente in chiusura Nm	30	30	35	35	40	45	45	60	65	70
Perdite di carico Kvs	107	250	430	790	1.250	1.960	2.790	2.880	4.306	6.380

IT_105bzn - Edizione 11/2018 • Maran e Peracini srl si riserva il diritto di apportare variazioni senza preavviso.